

PART OF SECTIONS 10 & 11,
TOWNSHIP 17 NORTH, RANGE 20 EAST, W.M.

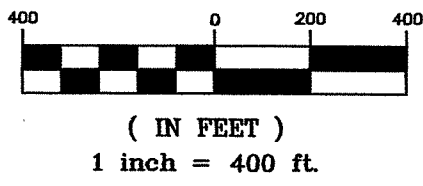

GRAPHIC SCALE



LEGEND

- SET 5/8" REBAR W/ YELLOW CAP - "CRUSE 36815"
- FOUND PIN & CAP AS NOTED
- x — FENCE

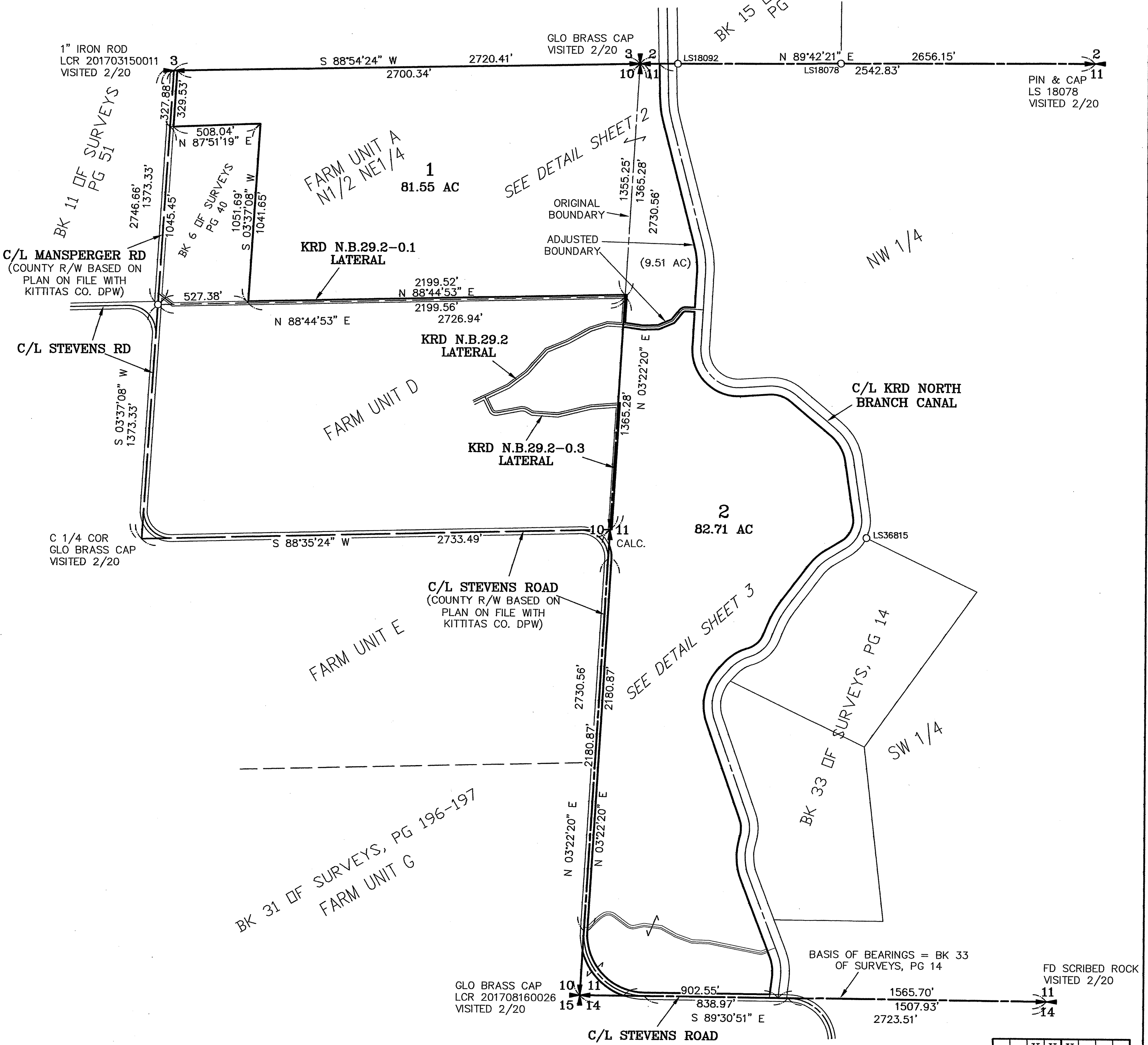

SHEET 1 OF 4

	X	X	X	
		X	X	
10				11
		X	X	
		X		

AUDITOR'S CERTIFICATE
 Filed for record this _____ day of _____
 2020, at _____ M., in Book 42 of Surveys at
 page(s) _____ at the request of Cruse & Associates.
 JERALD V. PETTIT BY: _____
 KITTITAS COUNTY AUDITOR

SURVEYOR'S CERTIFICATE
 This map correctly represents a survey made by me or
 under my direction in conformance with the requirements
 of the Survey Recording Act at the request of
 SAGE SHELTON in DECEMBER of 2019.
 CHRISTOPHER C. CRUSE
 Professional Land Surveyor
 DATE _____
 License No. 36815

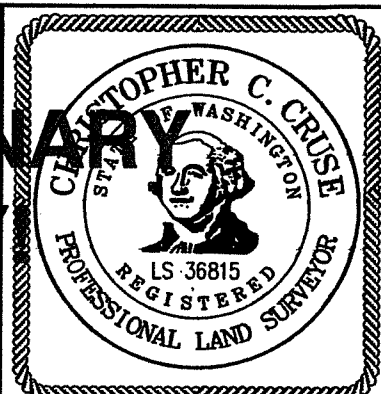

CRUSE & ASSOCIATES
 PROFESSIONAL LAND SURVEYORS
 217 East Fourth Street P.O. Box 959
 Ellensburg, WA 98926 (509) 962-8242
SHELTON/CLERF PROP.

**PRELIMINARY
 ONLY**

PART OF SECTIONS 10 & 11,
TOWNSHIP 17 NORTH, RANGE 20 EAST, W.M.

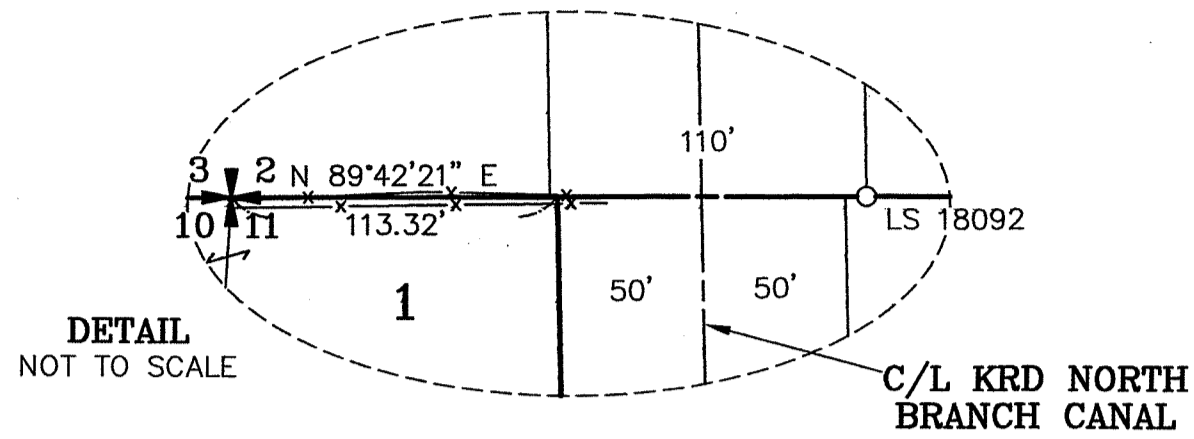
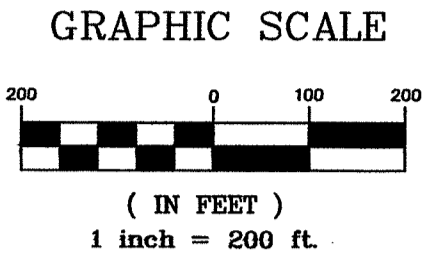

- LEGEND
- SET 5/8" REBAR W/ YELLOW CAP - "CRUSE 36815"
 - FOUND PIN & CAP AS NOTED
 - x — FENCE

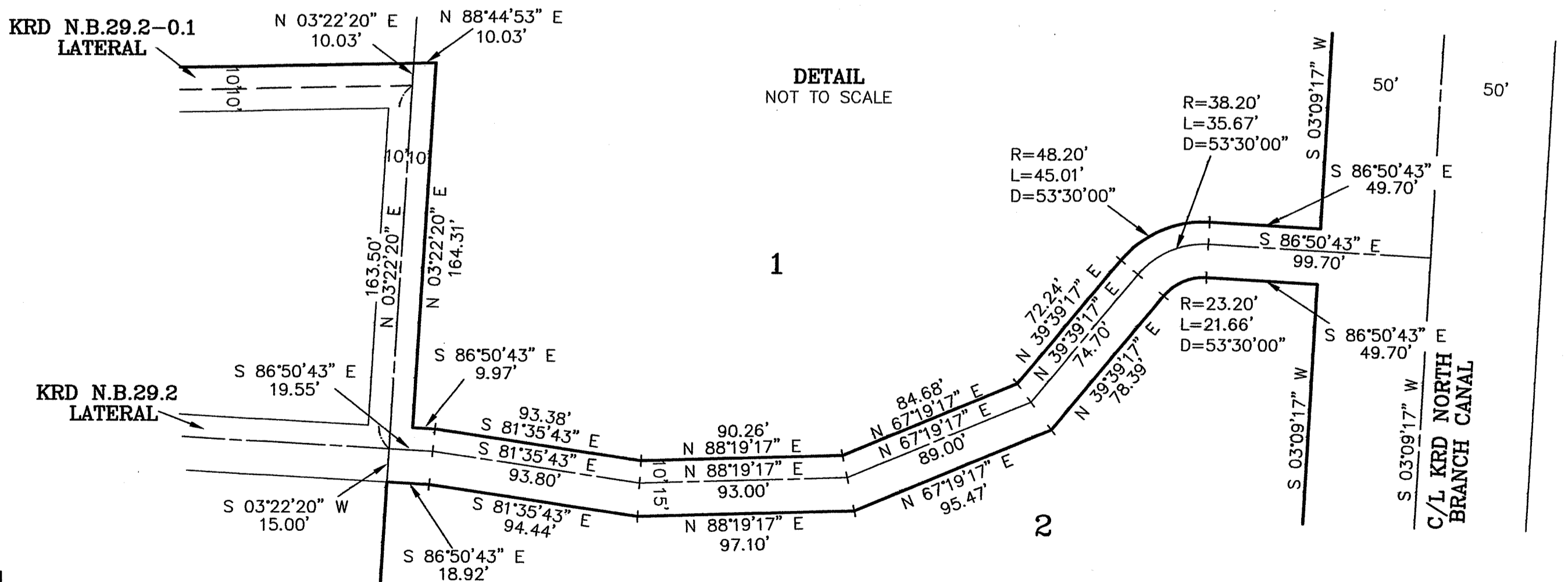
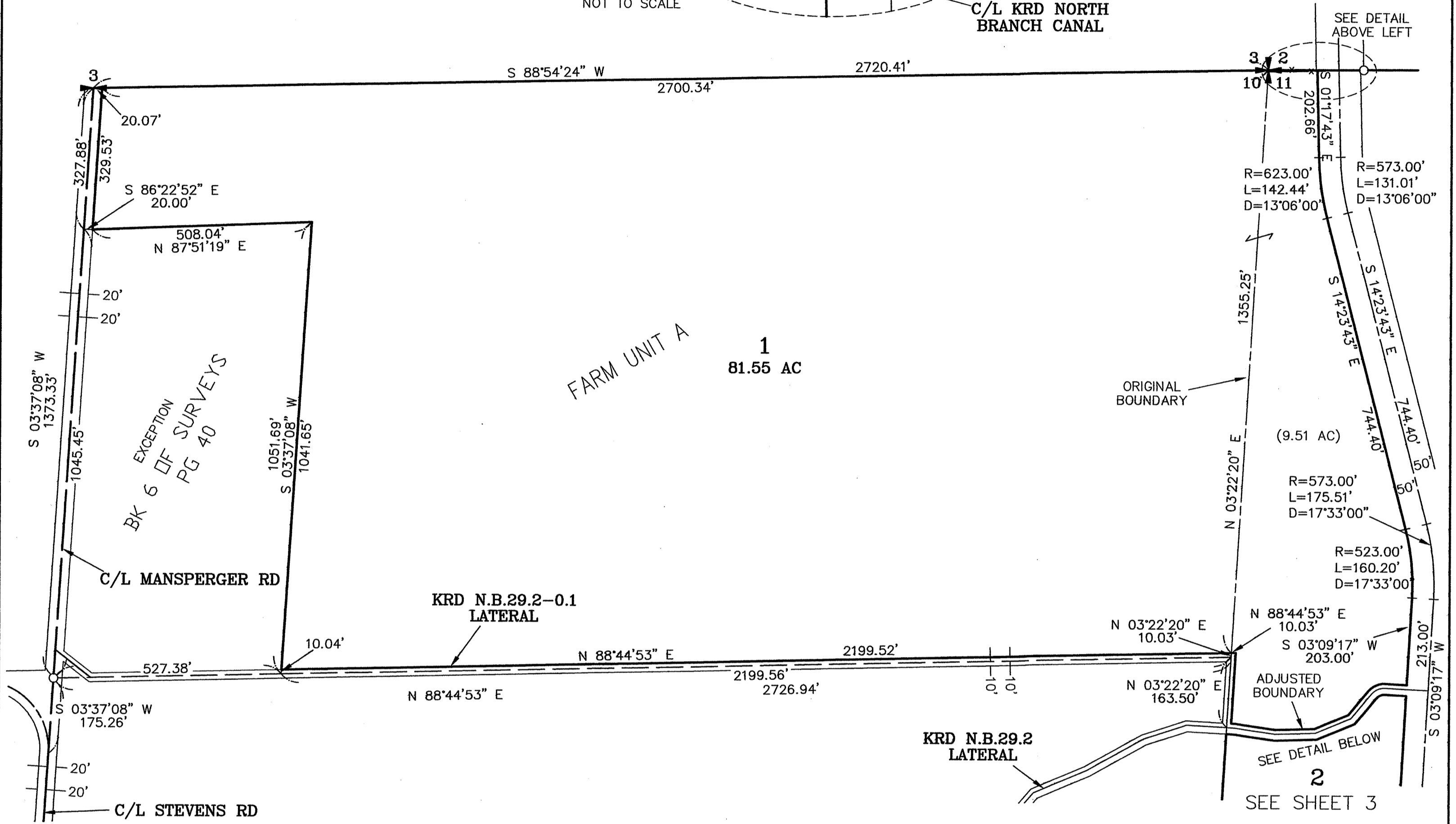

SHEET 2 OF 4

AUDITOR'S CERTIFICATE

Filed for record this _____ day of _____
2020, at _____ M., in Book 42 of Surveys at
page(s) _____ at the request of Cruse & Associates.

JERALD V. PETTIT BY: _____
KITITAS COUNTY AUDITOR

SURVEYOR'S CERTIFICATE

This map correctly represents a survey made by me or
under my direction in conformance with the requirements
of the Survey Recording Act at the request of
SAGE SHELTON in DECEMBER of 2019.

CHRISTOPHER C. CRUSE
Professional Land Surveyor

DATE _____
License No. 36815

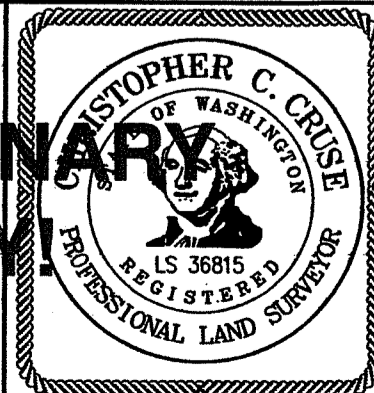

CRUSE & ASSOCIATES
PROFESSIONAL LAND SURVEYORS
217 East Fourth Street P.O. Box 959
Ellensburg, WA 98926 (509) 962-8242

SHELTON/CLERF PROP.

PRELIMINARY ONLY!

PART OF SECTIONS 10 & 11,
TOWNSHIP 17 NORTH, RANGE 20 EAST, W.M.



LEGEND

- SET 5/8" REBAR W/ YELLOW CAP - "CRUSE 36815"
- FOUND PIN & CAP AS NOTED
- x — FENCE

GRAPHIC SCALE

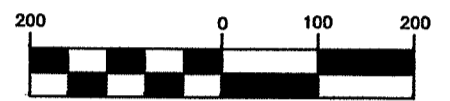

(IN FEET)
1 inch = 200 ft.

- L1 N 16°33'09" E 6.50'
- L2 N 42°31'09" E 56.00'
- L3 N 72°37'09" E 12.40'
- L4 N 21°59'09" E 58.40'
- L5 N 16°33'09" E 6.50'
- L6 N 72°37'09" E 12.40'
- L7 N 21°59'09" E 58.40'

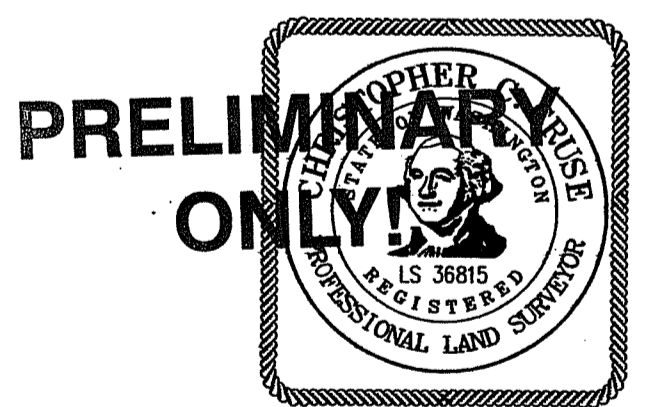

AUDITOR'S CERTIFICATE

Filed for record this _____ day of _____
2020, at _____ M., in Book 42 of Surveys at
page(s) _____ at the request of Cruse & Associates.

JERALD V. PETTIT BY:
KITITAS COUNTY AUDITOR

CRUSE & ASSOCIATES
PROFESSIONAL LAND SURVEYORS
217 East Fourth Street P.O. Box 959
Ellensburg, WA 98926 (509) 962-8242

SHELTON/CLERF PROP.

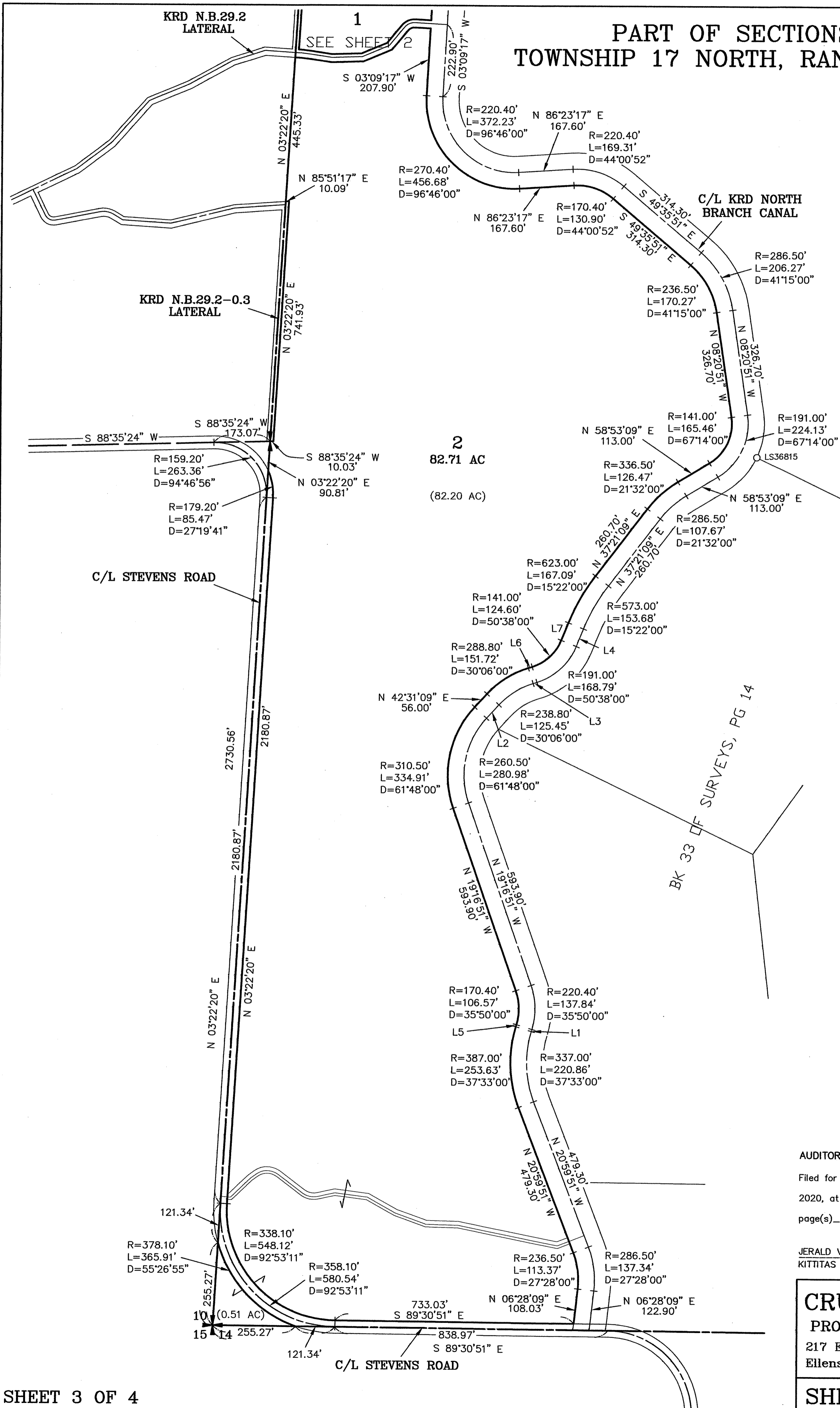

PART OF SECTIONS 10 & 11, TOWNSHIP 17 NORTH, RANGE 20 EAST, W.M.

NOTES:

1. THIS SURVEY WAS PERFORMED USING A TOPCON GTS SERIES TOTAL STATION AND/OR SURVEY GRADE GPS. ACCURACY COMPLIES WITH THE REQUIREMENTS SPECIFIED IN WAC 332-130-080 AND 090.
2. THIS SURVEY MAY NOT SHOW ALL EASEMENTS OR IMPROVEMENTS WHICH MAY PERTAIN TO THIS PROPERTY.
3. ACCORDING TO KITTITAS RECLAMATION DISTRICT (KRD) RECORDS, PARCEL 1 HAS _ IRRIGABLE ACRES; PARCEL 2 HAS _ IRRIGABLE ACRES. KRD WATER MAY ONLY BE APPLIED TO IRRIGABLE ACREAGE.
4. FULL PAYMENT OF ANNUAL KRD ASSESSMENT IS REQUIRED REGARDLESS OF THE USE OR NON-USE OF WATER BY THE OWNER.
5. THE LANDOWNERS MUST PROVIDE FOR THE APPOINTMENT OF ONE WATER MASTER FOR EACH TURNOUT, WHO SHALL BE RESPONSIBLE FOR ORDERING WATER FOR THE ENTIRE PROPERTY. THE MASTER WILL BE RESPONSIBLE FOR KEEPING WATER USE RECORDS FOR EACH LOT. KRD WILL ONLY BE RESPONSIBLE FOR KEEPING RECORDS ON THE TOTAL WATER ORDERED AT THE KRD TURNOUT.
6. KRD OPERATIONS AND MAINTENANCE ROADS ARE FOR DISTRICT USE ONLY. RESIDENTIAL AND RECREATIONAL USE IS PROHIBITED.
7. KRD IS ONLY RESPONSIBLE FOR DELIVERY OF WATER TO THE HIGHEST FEASIBLE POINT IN EACH 160 ACRE UNIT OR DESIGNATED TURNOUT. THE KRD IS NOT RESPONSIBLE FOR WATER DELIVERY LOSS (SEEPAGE, EVAPORATION, ETC.) BELOW THE DESIGNATED TURNOUT.
8. AN IRRIGATION EASEMENT 10 FEET IN WIDTH IS RESERVED ALONG ALL LOT LINES. THE 10 FOOT EASEMENT SHALL ABUT THE EXTERIOR PROPERTY BOUNDARY AND SHALL BE DIVIDED 5 FEET ON EACH SIDE OF INTERIOR LOT LINES.
9. KITTITAS COUNTY WILL NOT ACCEPT PRIVATE ROADS FOR MAINTENANCE AS PUBLIC STREETS OR ROADS UNTIL SUCH STREETS OR ROADS ARE BROUGHT INTO CONFORMANCE WITH CURRENT COUNTY ROAD STANDARDS. THIS REQUIREMENT WILL INCLUDE THE HARD SURFACE PAVING OF ANY STREET OR ROAD SURFACED ORIGINALLY WITH GRAVEL.
10. THE PURPOSE OF THIS SURVEY IS TO DELINEATE ADJUSTED PARCELS AND PROVIDE NEW DESCRIPTIONS FOR KITTITAS COUNTY BOUNDARY LINE ADJUSTMENT BL-20-00001. NO CORNERS WERE SET FOR THIS SURVEY AS THE NEW BOUNDARY IS TO FOLLOW KRD NB 29.2 LATERAL THAT IS CLEARLY OBSERVED IN THE FIELD.
11. FOR SECTION SUBDIVISION, CORNER DOCUMENTATION AND ADDITIONAL INFORMATION, SEE BOOK 6 OF SURVEYS, PAGE 40, AND THE SURVEYS REFERENCED HEREON.

LEGAL DESCRIPTIONS

ORIGINAL PARCEL DESCRIPTIONS

TAX PARCEL NO. 850633 (SHELTON)

FARM UNIT "A" ACCORDING TO U.S.D.I. BUREAU OF RECLAMATION FARM UNIT PLAT, BEING THE NORTH HALF OF THE NORTHEAST QUARTER OF SECTION 10, TOWNSHIP 17 NORTH, RANGE 20 EAST, W.M., IN THE COUNTY OF KITTITAS, STATE OF WASHINGTON.

EXCEPT

1. RIGHT OF WAY OF COUNTY ROAD (MANSPERGER ROAD) ALONG THE WEST BOUNDARY AND A PORTION OF THE NORTH BOUNDARY THEREOF.
2. RIGHT OF WAY OF THE KITTITAS RECLAMATION DISTRICT CANAL AS DISCLOSED BY APPRAISAL OF LANDS RECORDED APRIL 15, 1943, IN BOOK 66 OF DEEDS, PAGE 157.
3. BEGINNING AT THE NORTHWEST CORNER OF THE NORTHEAST QUARTER OF SAID SECTION; THENCE SOUTH 03°41'48" WEST ALONG THE WEST BOUNDARY OF SAID QUARTER, 327.88 FEET TO THE TRUE POINT OF BEGINNING OF THIS EXCEPTION; THENCE SOUTH 85°18'12" EAST, 20 FEET; THENCE NORTH 87°55'59" EAST, 508.04 FEET; THENCE SOUTH 03°41'48" WEST, 1051.66 FEET, MORE OR LESS, TO THE SOUTH BOUNDARY LINE OF THE NORTH HALF OF THE NORTHEAST QUARTER OF SAID SECTION; THENCE WEST ALONG SAID SOUTH BOUNDARY LINE TO THE WEST BOUNDARY LINE OF SAID NORTH HALF OF THE NORTHEAST QUARTER; THENCE NORTH ALONG SAID WEST BOUNDARY LINE TO THE TRUE POINT OF BEGINNING.

TAX PARCEL NO. 200633 (CLERF)

ALL OF THAT PORTION OF THE NORTHWEST QUARTER OF THE SOUTHWEST QUARTER LYING WEST AND SOUTH OF THE KITTITAS RECLAMATION DISTRICT "TURBINE DITCH," ALL IN SECTION 11, TOWNSHIP 17 NORTH, RANGE 20 EAST, W.M., KITTITAS COUNTY, WASHINGTON, CONTAINING 25.90 ACRES MORE OR LESS.

AND

THAT PORTION OF THE WEST HALF OF THE NORTHWEST QUARTER LYING WEST AND BELOW THE KITTITAS RECLAMATION DISTRICT IN SECTION 11, TOWNSHIP 17 NORTH, RANGE 20 EAST, W.M., IN THE COUNTY OF KITTITAS, STATE OF WASHINGTON.

AND

THAT PORTION OF THE SOUTHWEST QUARTER OF THE SOUTHWEST QUARTER LYING BELOW THE KITTITAS RECLAMATION DISTRICT CANAL IN SECTION 11, TOWNSHIP 17 NORTH, RANGE 20 EAST, W.M., IN THE COUNTY OF KITTITAS, STATE OF WASHINGTON.

EXCEPT ANY COUNTY ROAD RIGHT-OF-WAYS.

ADJUSTED PARCEL DESCRIPTIONS

PARCEL 1 (SHELTON)

PARCEL 1 OF THAT CERTAIN SURVEY RECORDED FEBRUARY ____, 2020, IN BOOK 42 OF SURVEYS AT PAGES _____, UNDER AUDITOR'S FILE NO. 202002_____, RECORDS OF KITTITAS COUNTY, STATE OF WASHINGTON; BEING A PORTION OF THE NORTH HALF OF THE NORTHEAST QUARTER OF SECTION 10, AND A PORTION OF THE WEST HALF OF THE NORTHWEST QUARTER OF SECTION 11, ALL IN TOWNSHIP 17 NORTH, RANGE 20 EAST, W.M., IN THE COUNTY OF KITTITAS, STATE OF WASHINGTON.

PARCEL 2 (CLERF)

PARCEL 2 OF THAT CERTAIN SURVEY RECORDED FEBRUARY ____, 2020, IN BOOK 42 OF SURVEYS AT PAGES _____, UNDER AUDITOR'S FILE NO. 202002_____, RECORDS OF KITTITAS COUNTY, STATE OF WASHINGTON; BEING A PORTION OF THE WEST HALF OF THE NORTHWEST QUARTER OF SECTION 11, TOWNSHIP 17 NORTH, RANGE 20 EAST, W.M., IN THE COUNTY OF KITTITAS, STATE OF WASHINGTON.

SHEET 4 OF 4

AUDITOR'S CERTIFICATE

Filed for record this _____ day of _____, 2020, at _____ M., in Book 42 of Surveys at page(s) _____ at the request of Cruse & Associates.

JERALD V. PETTIT BY: _____
KITTITAS COUNTY AUDITOR

SURVEYOR'S CERTIFICATE

This map correctly represents a survey made by me or under my direction in conformance with the requirements of the Survey Recording Act at the request of SAGE SHELTON in DECEMBER of 2019.

CHRISTOPHER C. CRUSE
Professional Land Surveyor

DATE
License No. 36815

PRELIMINARY
ONLY!

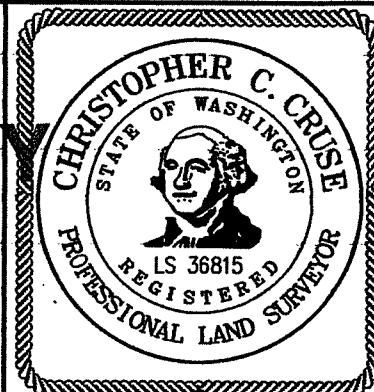

**CRUSE & ASSOCIATES
PROFESSIONAL LAND SURVEYORS**

217 East Fourth Street P.O. Box 959
Ellensburg, WA 98926 (509) 962-8242

SHELTON/CLERF PROP.